

TOP VIEW

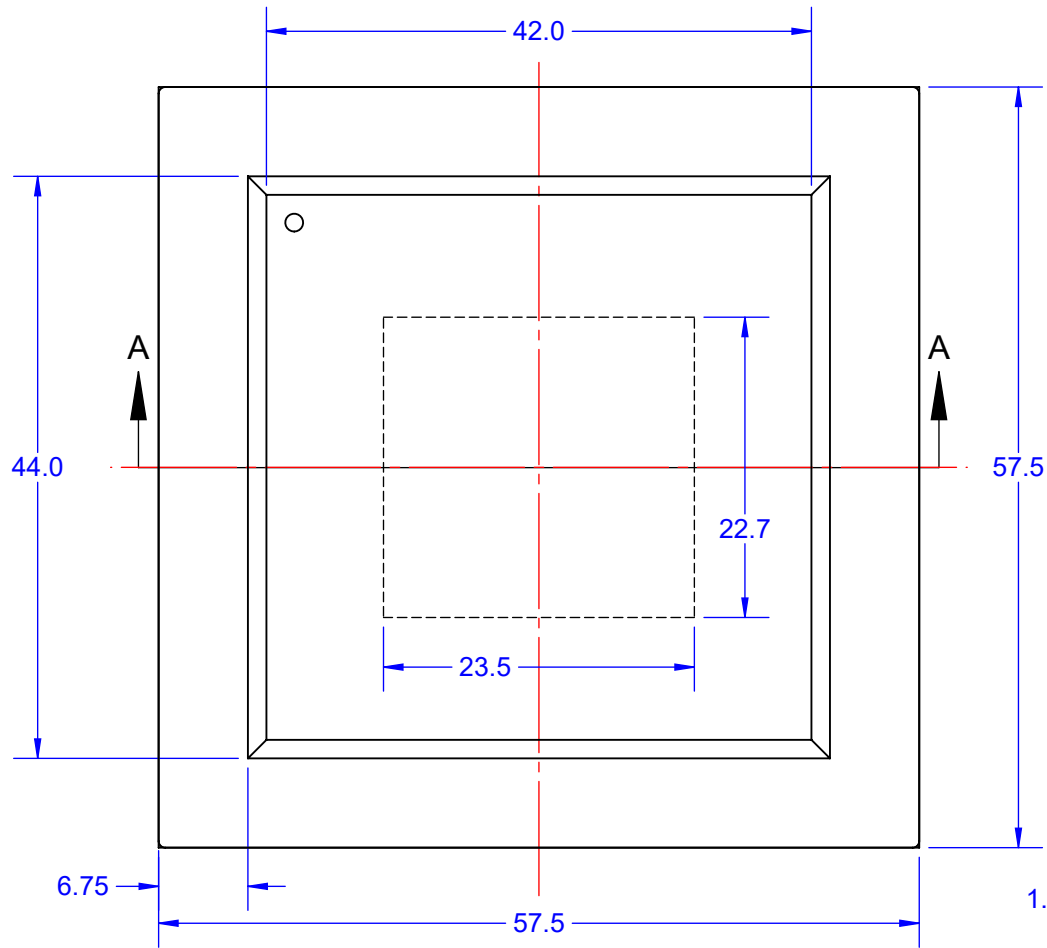

BOTTOM VIEW

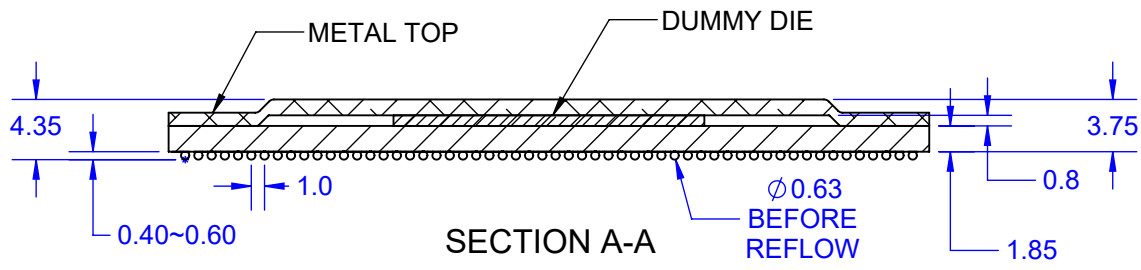
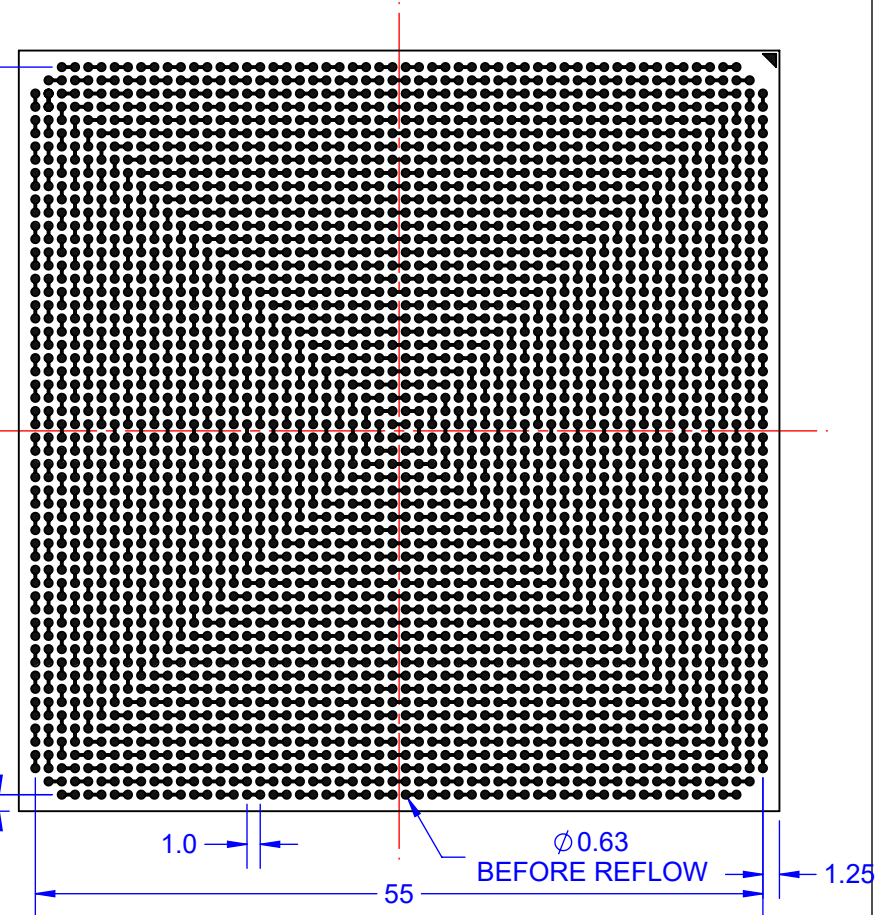

Notes: (Unless Otherwise Specified).

- 1) ALL DIMENSIONS: MM.
- 2) SOLDER BALL ALLOY: SEE PART NUMBER TABLE.
- 3) BALL DIAMETER (BEFORE REFLOW): 0.635mm (25 MIL).
- 4) SOLDER MASK DEFINED PAD OPENING: 0.50mm (19.7 MIL).
- 5) PAD Cu DIAMETER: 0.635mm (25 MIL).
- 6) SUBSTRATE MATERIAL: BT.
- 7) DUMMY DIE Si (SILICON) 23. x 22.7mm.
- 8) DAISY CHAIN PATTERN (SEE PAGE 2).
- 9) MSL-3 RECOMMENDED BAKING 24 HOURS @ 125°C TO REMOVE MOISTURE PRIOR SOLDERING TO PC BOARD.

PART NUMBER TABLE				
PART NUMBER	BALL ALLOY	BALL ALLOY	RoHS	Si DIE
SBGA3124T1.0C-DC567D	Sn96.5/Ag3.0/Cu0.5	SAC305	YES	YES
SBGA3124T1.0-DC567D	Sn63/Pb37	Sn63	NO	YES

APPROVALS	DATE	TopLine®			
DRAWN T. Au	2/11/2023				
ENG M. Hart	2/11/2023	TITLE SBGA3124T1.0-DC567D DAISY CHAIN DUMMY			
MFG		SCALE	SIZE	DRAWING NO.	REV
QA		1.75:1	A	515675	A
CUST		DO NOT SCALE DRAWING			SHEET 1 OF 6
REVISED					

BALL VIEW

56 54 52 50 48 46 44 42 40 38 36 34 32 30 28 26 24 22 20 18 16 14 12 10 8 6 4 2
 55 53 51 49 47 45 43 41 39 37 35 33 31 29 27 25 23 21 19 17 15 13 11 9 7 5 3 1

PIN A1

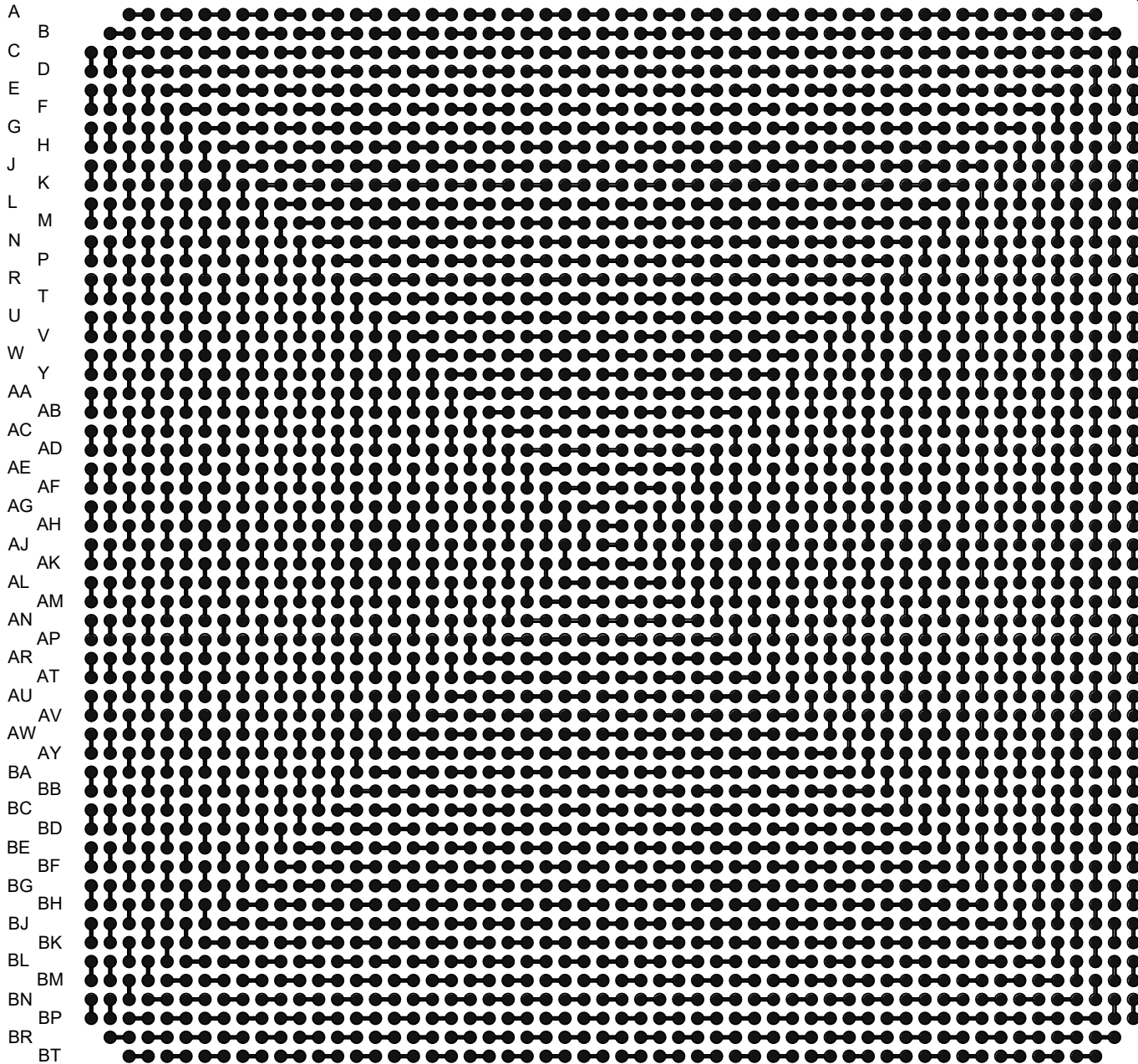

TopLine®			
TITLE		SBGA3124T1.0-DC567D DAISY CHAIN DUMMY	
SCALE	SIZE	DRAWING NO.	REV
3:1	A	515675	A
DO NOT SCALE DRAWING			SHEET 2 OF 6

HEAT SPREADER

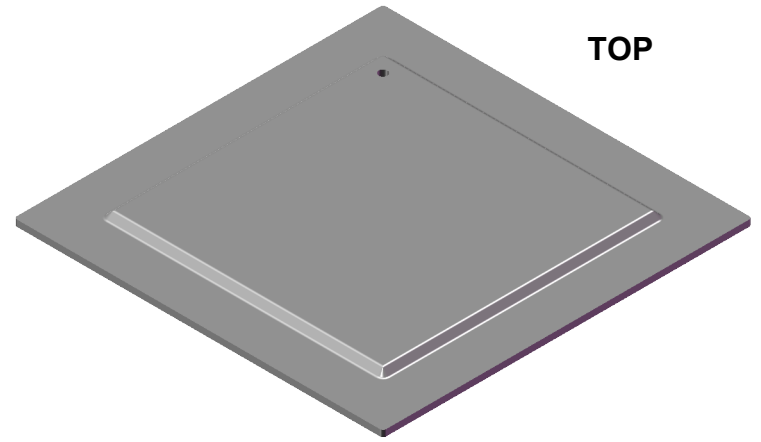
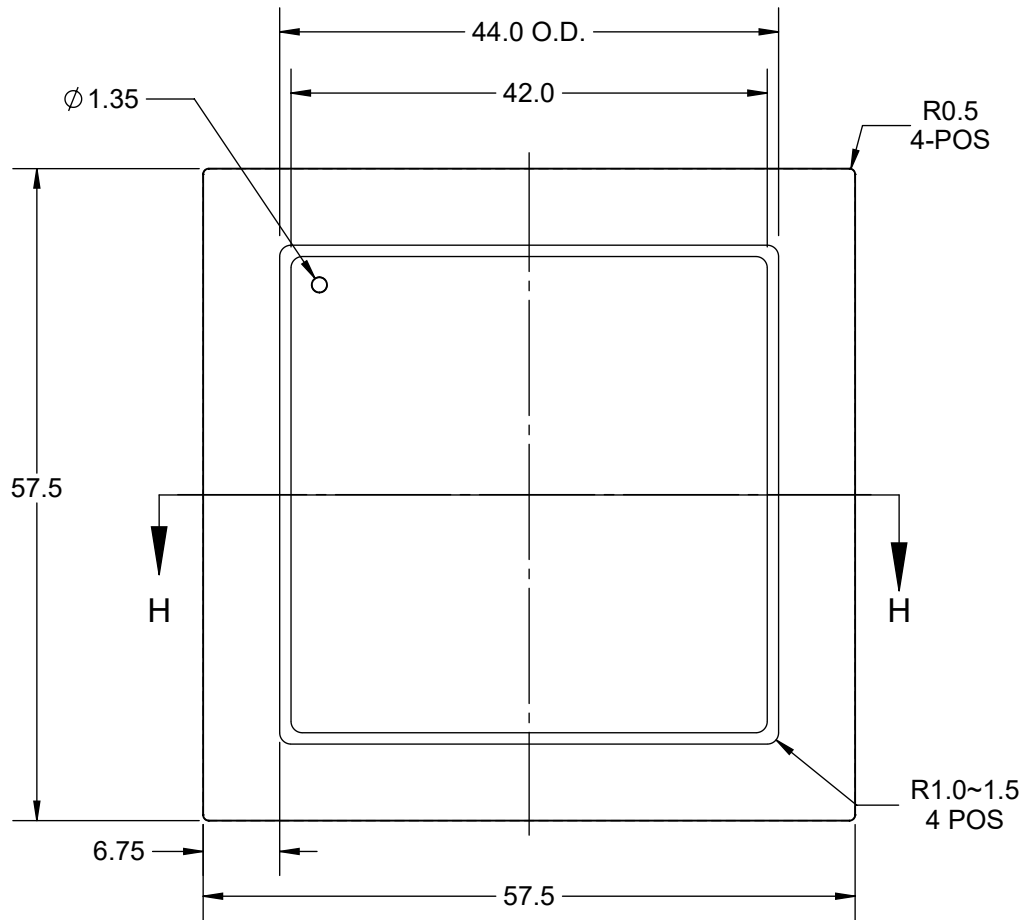

TOP

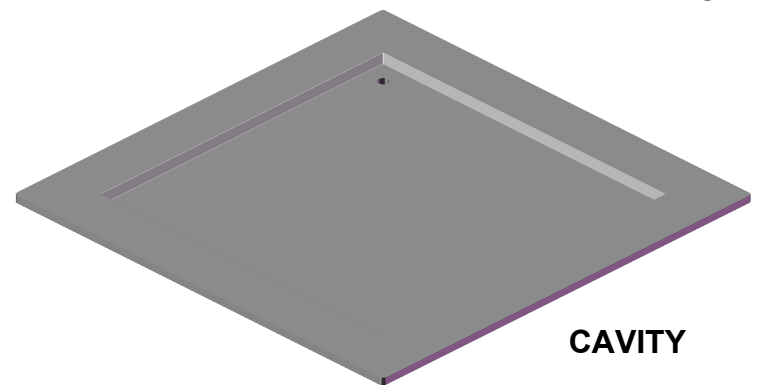

MODEL

CAVITY

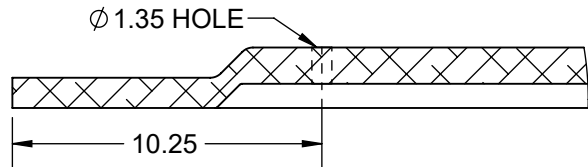

DETAIL F
SCALE 4 : 1

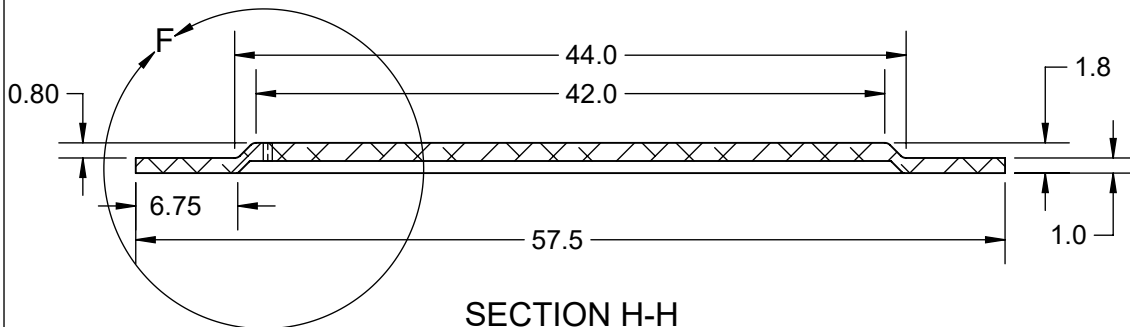

SECTION H-H

NOTES:

1. DIMENSIONS mm
2. MATERIAL: COPPER ALLOY C1020 OR C1100
HALF HARD, OXYGEN FREE
3. PLATING: NICKEL 5um MIN (SEMI FINISH)
4. PERIMETER EDGE IS UNPLATED.

APPROVALS	DATE	TopLine®			
DRAWN T. Au	2/06/2023				
ENG M. Hart	2/06/2023	TITLE H-CAP - 57.5mm HEAT SPREADER			
MFG		SCALE	SIZE	DRAWING NO.	REV
QA		3:1	A	257710	A
CUST		DO NOT SCALE DRAWING			SHEET 4 OF 6
REVISED					

MODEL

TOP

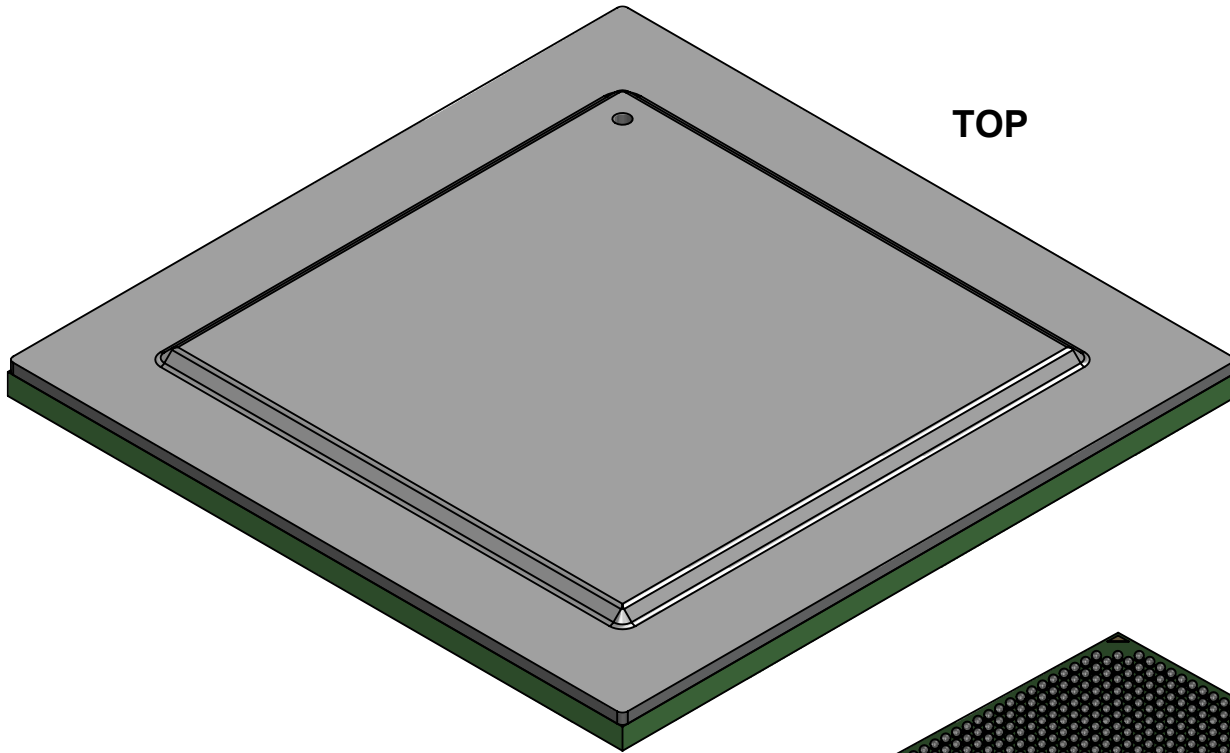

BALL VIEW

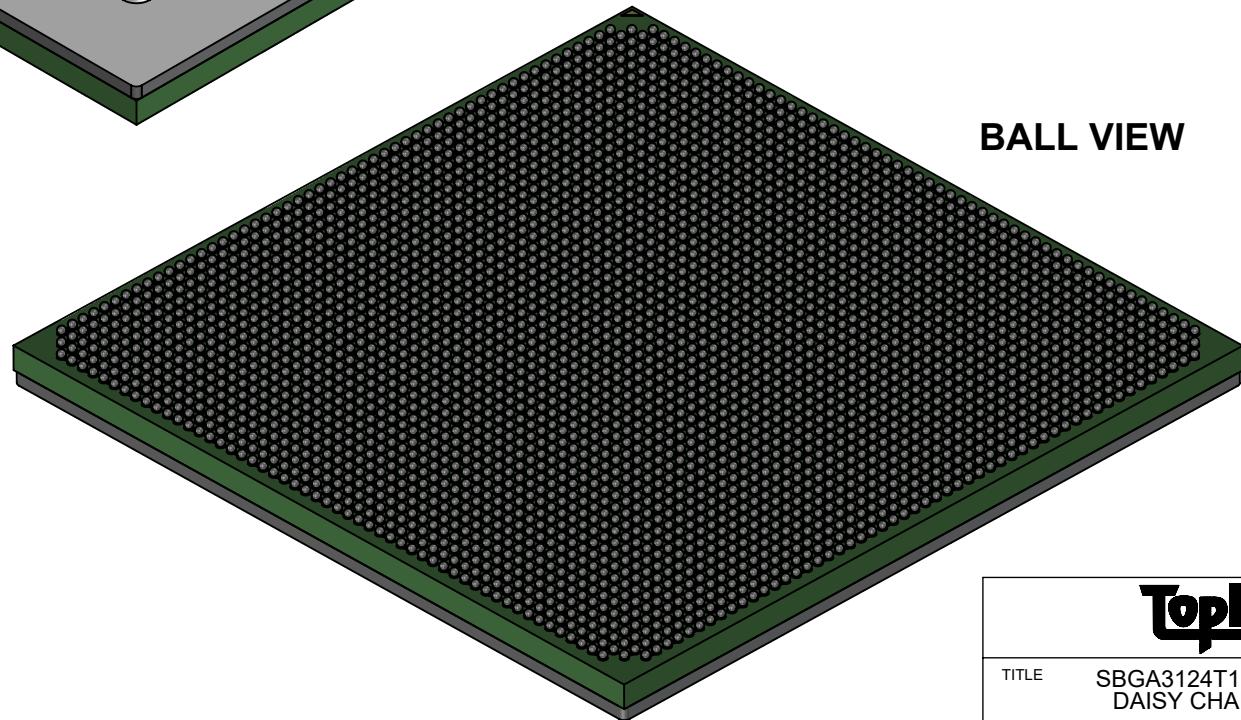

TopLine[®]

TITLE SBGA3124T1.0-DC567D
DAISY CHAIN DUMMY

SCALE 2:1	SIZE A	DRAWING NO. 515675	REV A
--------------	-----------	-----------------------	----------

DO NOT SCALE DRAWING

SHEET 5 OF 6

BOTTOM SOLDERMASK (RIGHT READING)

56 54 52 50 48 46 44 42 40 38 36 34 32 30 28 26 24 22 20 18 16 14 12 10 8 6 4 2
55 53 51 49 47 45 43 41 39 37 35 33 31 29 27 25 23 21 19 17 15 13 11 9 7 5 3 1

PIN A1

A
B
C
D
E
F
G
H
J
K
L
M
N
P
R
T
U
V
W
Y
AA
AB
AC
AD
AE
AF
AG
AH
AJ
AK
AL
AM
AN
AP
AR
AT
AU
AV
AW
AY
BA
BB
BC
BD
BE
BF
BG
BH
BJ
BK
BL
BM
BN
BP
BR
BT

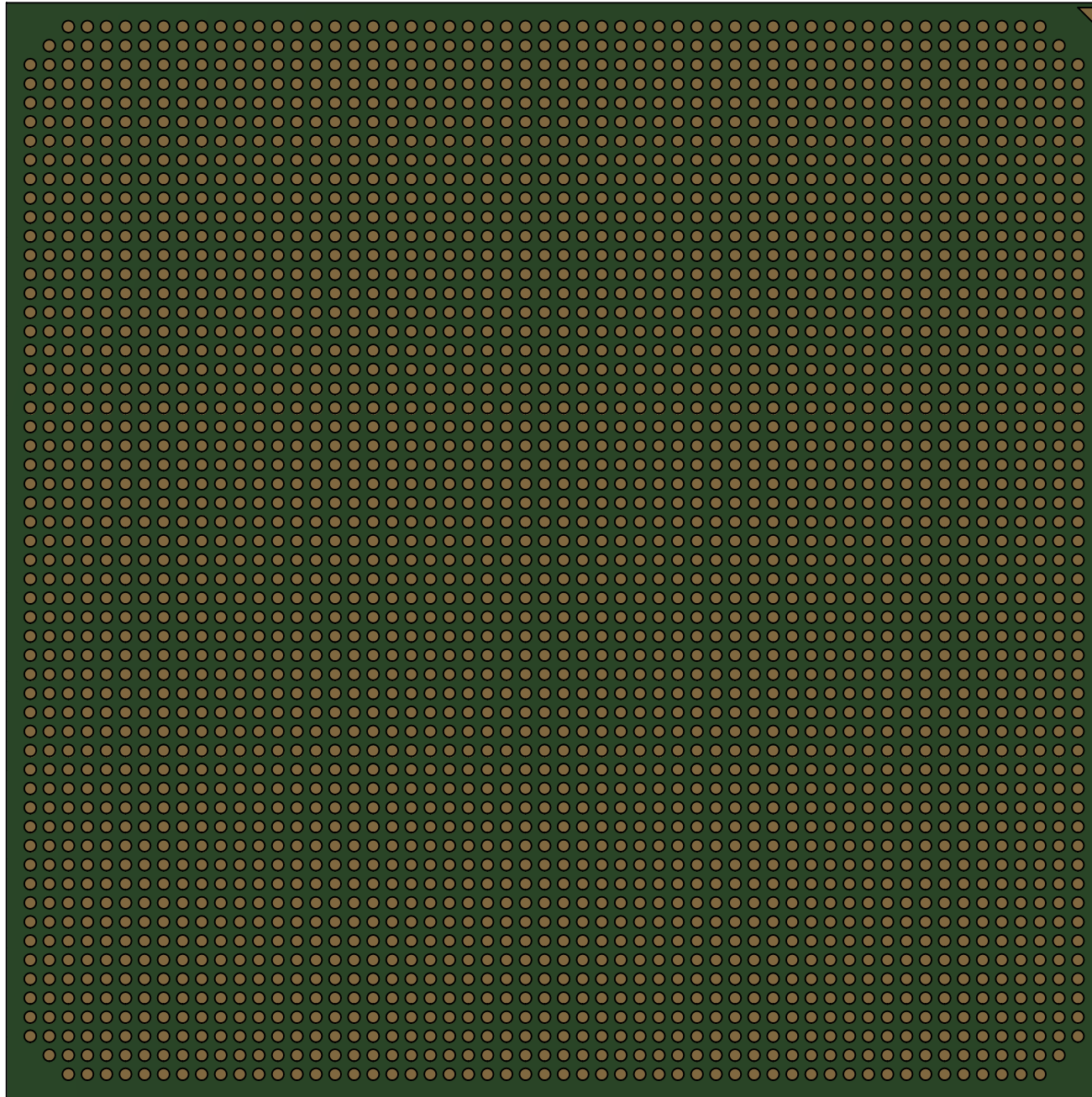

TopLine®			
TITLE		SBA3124T1.0-DC567D DAISY CHAIN DUMMY	
SCALE	SIZE	DRAWING NO.	REV
3:1	A	515675	A
DO NOT SCALE DRAWING			SHEET 6 OF 6